

MELODÍA 1

música 1 *primaria*

Índice

UNIDAD 1: LOS DUENDES ZAPATEROS

CUENTO MUSICADO:	<i>Los duendes zapateros.</i>	4	INTERPRETACIÓN MUSICAL:	Sílabas rítmicas.	10
CANCIÓN:	<i>Zapatero remendón.</i>	5	MÚSICA Y CULTURA:	Instrumentos de percusión.	11
INTERPRETACIÓN MUSICAL:	La música de nuestro cuerpo.	6	CANTAMOS Y DRAMATIZAMOS:	<i>La cabeza sí, la cabeza no.</i>	12-13
Lenguaje musical:	Sonidos largos y cortos.	7	AUDICIÓN PARA DRAMATIZAR:	<i>Los canguros.</i>	14
	El pentagrama.	8	AUDICIÓN:	<i>The Quiddich World Cup.</i>	15
	La clave de sol.	9			

UNIDAD 2: LA NAVIDAD DE LOS CUENTOS

CUENTO MUSICADO:	<i>La Navidad de los cuentos.</i>	16	INTERPRETACIÓN MUSICAL:	Posibilidades sonoras de nuestra voz.	23
CANCIÓN:	<i>En el Reino de los Cuentos.</i>	17	MÚSICA Y CULTURA:	Instrumentos de percusión.	24
LOS SONIDOS DE NUESTRO ENTORNO:	La calle.	18	CANTAMOS Y BAILAMOS:	<i>El otoño ya se acerca.</i>	25
Lenguaje musical:	Sonidos fuertes y sonidos débiles.	19	MÚSICA Y CULTURA:	Instrumentos que acompañan las canciones de la Navidad.	26
	El pentagrama y la clave de sol.	20		La música nos inspira sentimientos.	27
	La negra y su silencio.	21	AUDICIÓN:	<i>Marcha Radetzky</i>	28-29
	Trabajamos con el ritmo.	22			

UNIDAD 3: LA ARDILLA HOLGAZANA

CUENTO MUSICADO:	<i>La ardilla holgazana</i>	30	INTERPRETACIÓN MUSICAL:	<i>No te muevas más.</i>	36
CANCIÓN:	<i>La ardilla holgazana</i>	31	MÚSICA Y CULTURA:	La voz y sus agrupaciones.	37
LOS SONIDOS DE NUESTRO ENTORNO:	El bosque.	32	INTERPRETACIÓN MUSICAL:	Instrumentos de percusión.	38
Lenguaje musical:	Sonidos graves y sonidos agudos.	33	CANTAMOS Y DRAMATIZAMOS:	Partitura para voces de animales.	39
	Las corcheas.	34	AUDICIÓN:	<i>Epo i tai</i>	40
	El pulso.	35		<i>Le basque</i>	41

UNIDAD 4: LA RATITA PRESUMIDA

CUENTO MUSICADO:	<i>La Ratita Presumida</i>	42	INTERPRETACIÓN MUSICAL:	<i>Vamos a la mar.</i>	47
CANCIÓN:	<i>La Ratita Presumida</i>	43	MÚSICA Y MOVIMIENTO:	Juego musical.	48
LOS SONIDOS DE			MÚSICA Y CULTURA:	Instrumentos de percusión.	49
NUESTRO ENTORNO:	La granja.	44	CANTAMOS Y BAILAMOS:	<i>Cucu.</i>	50
Lenguaje musical:	Sonidos largos y sonidos cortos.	45	MÚSICA Y CULTURA:	Dibujamos con la música.	51
	El ritmo y el pulso.	46	AUDICIÓN:	<i>Ballet de los polluelos.</i>	52-53

UNIDAD 5: CENICIENTA

CUENTO MUSICADO:	<i>Cenicienta.</i>	54	Lenguaje musical:	Las notas musicales y el pentagrama.	60
CANCIÓN:	<i>Ruke di gak.</i>	55	INTERPRETACIÓN MUSICAL:	<i>La pelota salta y bota.</i>	61
LOS SONIDOS DE			MÚSICA Y CULTURA:	Bailes y danzas populares.	62
NUESTRO ENTORNO:	La casa.	56		Cómo suenan los instrumentos.	63
Lenguaje musical:	Sonidos agudos, graves, largos y cortos.	57	CANTAMOS Y DRAMATIZAMOS:	<i>Tin, ton.</i>	64
	Las notas musicales.	58	AUDICIÓN:	<i>Danza húngara N° 5.</i>	65
	El pentagrama y las notas musicales.	59			

UNIDAD 6: EL SOLDADITO DE PLOMO

CUENTO MUSICADO:	<i>El soldadito de plomo.</i>	66	AUDICIÓN PARA DRAMATIZAR:	<i>Gallo y gallinas.</i>	73
CANCIÓN:	<i>El soldado de plomo.</i>	67	MÚSICA Y CULTURA:	Las familias de percusión.	74
LOS SONIDOS DE				De vacaciones por el mundo.	75
NUESTRO ENTORNO:	Las profesiones.	68	JUEGO MUSICAL:	<i>Antón Pirulero.</i>	76
Lenguaje musical:	Trabajamos con el ritmo.	69	MÚSICA Y CULTURA:	Los protagonistas de la música.	77
	La nota la	70	PASATIEMPO:	Sopa de instrumentos musicales.	78
INTERPRETACIÓN MUSICAL:	<i>Margarita tiene un gato.</i>	71	AUDICIÓN:	<i>Entrada de los gladiadores.</i>	79
MÚSICA Y CULTURA:	La música y los cuentos.	72			

1

LOS DUENDES ZAPATEROS





*Zapa zapa, zapatero
zapa, zapatón,
conocí a un zapatero,
que era un pobre remendón.*

*Zapataba todo el día,
zapataba sin parar;
para cuero no tenía
más dinero que un real.*

Zapa zapa zapatero...

*Una noche, unos duendes,
zapa, zapa, zapatón,
se ofrecieron a coserle
dos zapatos de impresión.*

Zapa zapa zapatero...

*Venga cola, venga cuero,
antes suela, ahora tacón;
reunió tanto dinero
que de pobre al fin salió.*

Zapa zapa zapatero...



Interpretación musical: La música de nuestro cuerpo

1 Escucha e identifica.

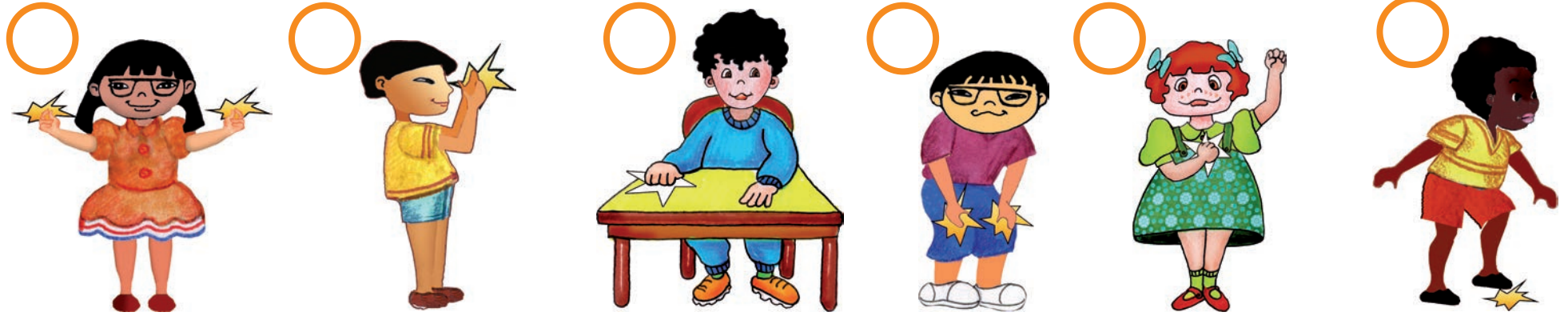

Con nuestro cuerpo podemos hacer sonidos o estar en silencio.

2 Interpreta estos ritmos.





Los sonidos pueden ser cortos o largos.

1  Escucha y observa.

 sonido largo

 sonido corto

2  Identifica e indica sonido largo o sonido corto















Lenguaje musical: El pentagrama

La música la escribimos en el pentagrama
El pentagrama tiene cinco líneas y cuatro espacios.

- 1 Repasa las líneas de marrón y colorea de azul los espacios. Después dibuja peces en los espacios y estrellas de mar en las líneas como en el ejemplo.

línea 5

línea 4

línea 3

línea 2

línea 1

espacio 4

espacio 3

espacio 2

espacio 1



La clave de sol sirve para nombrar las notas en el pentagrama.
Se coloca al principio del pentagrama.

1 Repasa la clave de sol.



Aprende el código:

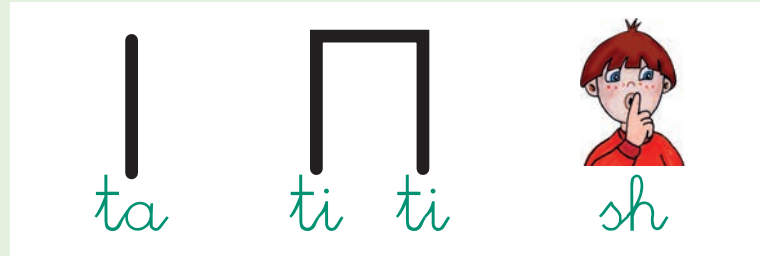

1 Observa y lee con las sílabas rítmicas. En  haz silencio.

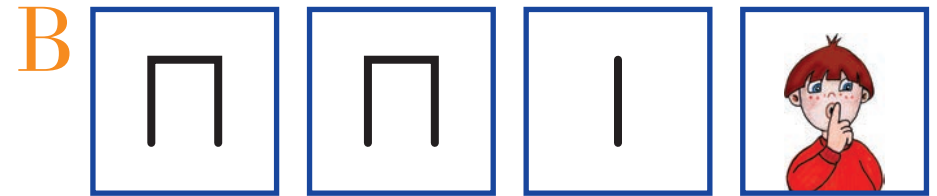
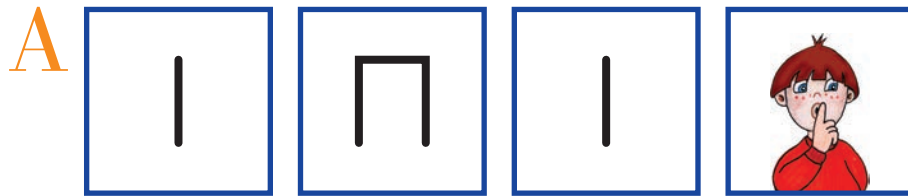

2 Ahora practica los ritmos anteriores con palmas.



1  Identifica y numera.

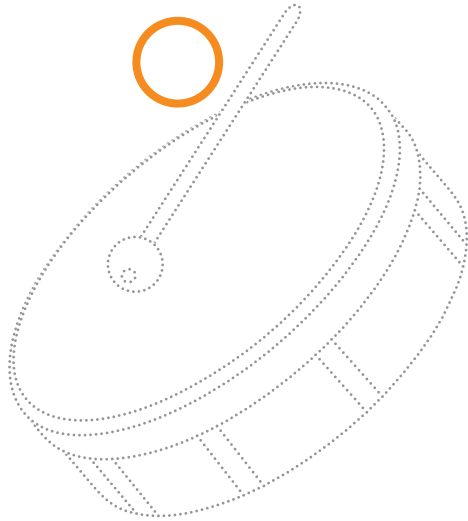

pandero

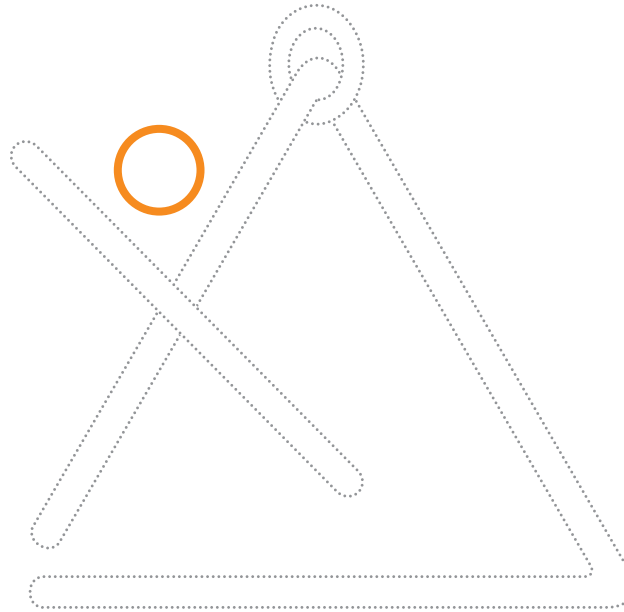

triángulo

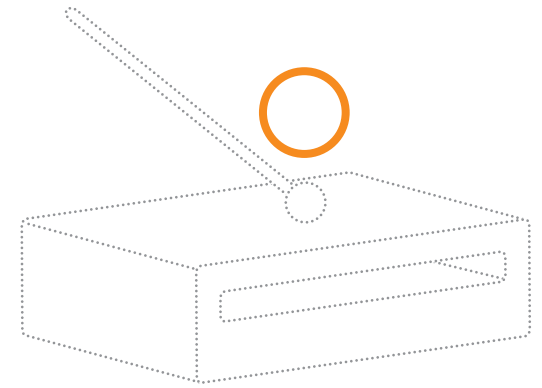

2 Repasa y colorea.























caja china

3 Practica estos ritmos con sílabas rítmicas, palmas e instrumentos.

Clave:

	ta
	ti ti



forma: Introducción - A - B - enlace - C - B - enlace - D - B - final.



Escucha la música de la canción antes de cantarla y dramatizarla.

Introducción y enlaces



A



B





A La cabeza en lo más alto
con el pelo alborotado
y dos ojos colocados,
cada uno en un lado.

B La cabeza sí, sí, sí,
la cabeza no, no, no;
con el movimiento
me divierto yo.

C Dos mejillas, dos orejas
que nos dejan escuchar
y estos dos agujeritos
nos permiten respirar.

B La cabeza sí, sí, sí [. .]

D Una frente, una barbilla,
una cueva singular;
en la puerta hay dos labios
y los dientes dentro están.

B La cabeza sí, sí, sí [. .]





forma: A - B - A - C - A - D

A



B



C



D

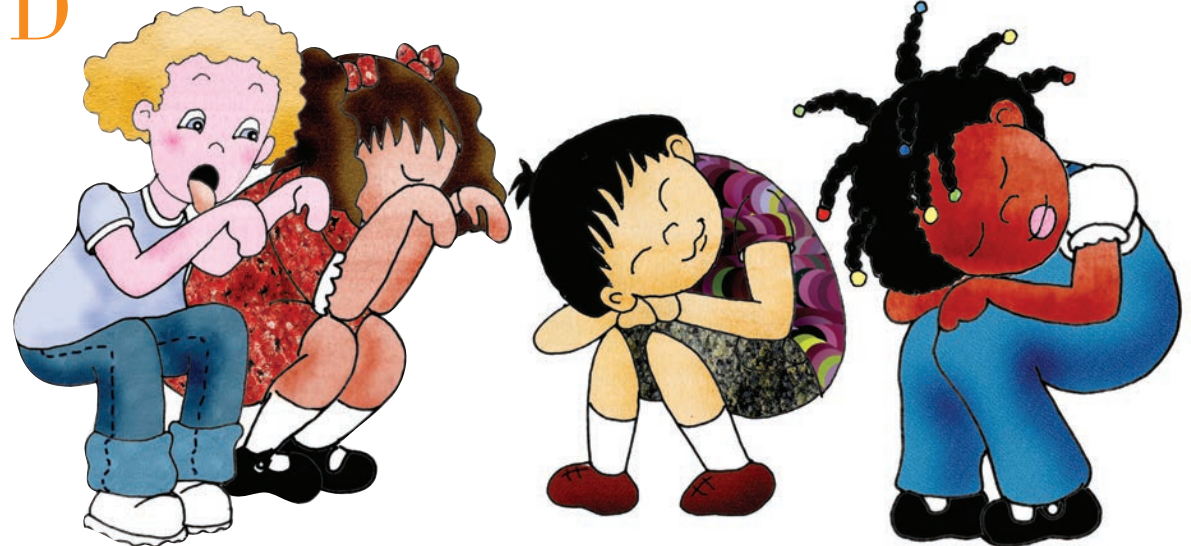



The Quiddich World Cup

Banda Sonora "Harry Potter y el Cáliz de Fuego"







Patrick Doyle
(1953-)

A ||: ||:

B ||: ||:

A ||: ||:





2

La Navidad de los cuentos

En el Reino de los Cuentos
ya llegó la Navidad;
todos juntos muy contentos
fueron al Niño a adorar.
En el Reino de los Cuentos...
ya llegó la Navidad...

Pulgarcito le llevaba,
unas migas de su pan.
Y tras él, Caperucita,
le llevaba un rico flan.
Blancanieves, un espejo;
una isla Peter Pan
y Pinocho una nariz
que estornuda de verdad.

En el Reino de los Cuentos...

Cenicienta le llevaba
un zapato de cristal,
una rosa el principito,
y un avión para volar.
La ratita presumida
un anillo de metal;
y el joven Cascanueces
una nuez de su nogal.

En el Reino de los Cuentos...





José Lueiro



Los sonidos pueden ser fuertes o suaves.

1  Escucha y observa.



2  Identifica e indica: sonido fuerte  o sonido suave 





Lenguaje musical: El pentagrama y la clave de sol

1 Colorea: 

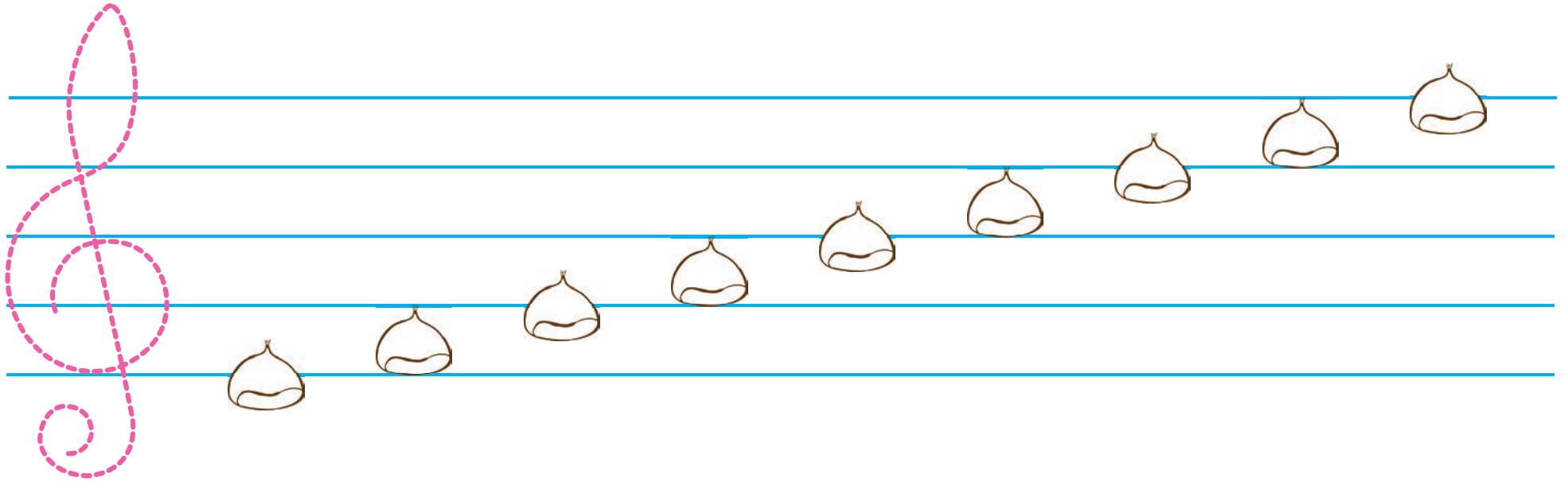

2 Practica la clave de sol.

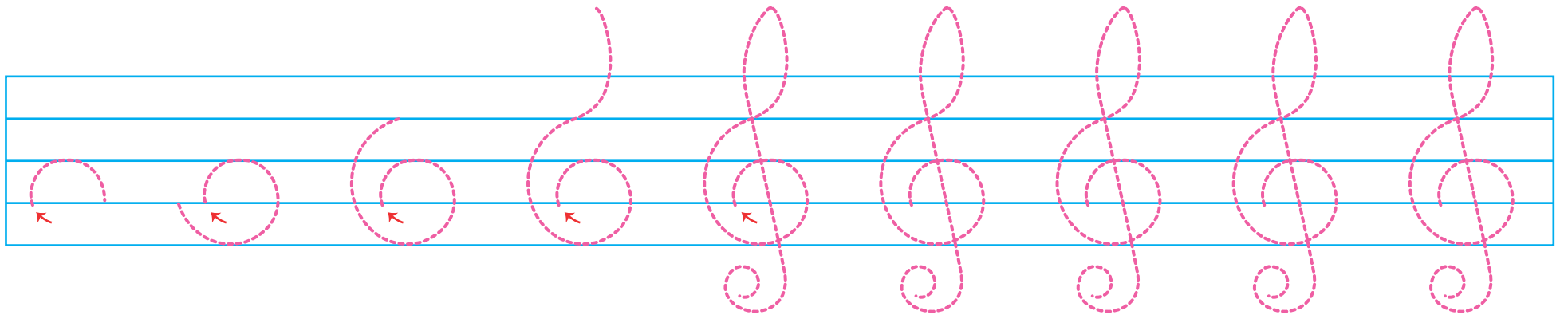



Estos signos los utilizamos para escribir música:

la negra

ta

cabeza →

← plica

el silencio de negra

sh

La negra dura un pulso. Su silencio también.

1 Dibuja las cabezas y coloréalas.

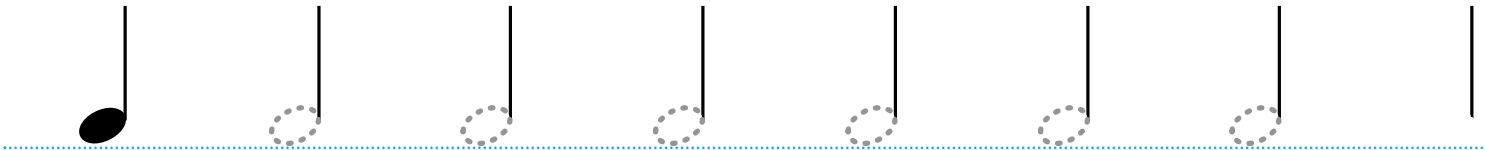

2 Dibuja las plicas y colorea las cabezas.



3 Practica la escritura del silencio.

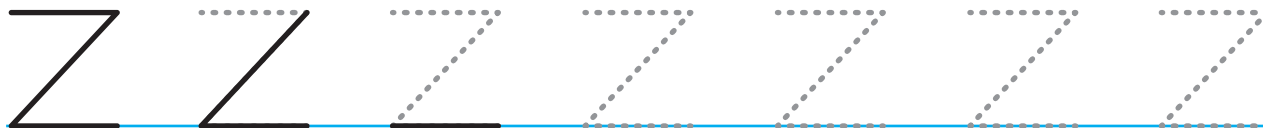



1 Repasa los ritmos, lee con las sílabas rítmicas y palméalalos.

A

B

C

D

2 Repasa la negra y su silencio.

Tic, tac, toc

yo soy un reloj

Me das cuerda y no me paro,

si te olvidas, ¡yo me enfado!





1 Una vez que aprendas el código, interpreta la partitura con tu voz.

C
Ó
D
I
G
O

 lluvia	 viento	 trueno	 silencio
--	--	--	--





1 Identifica y numera.

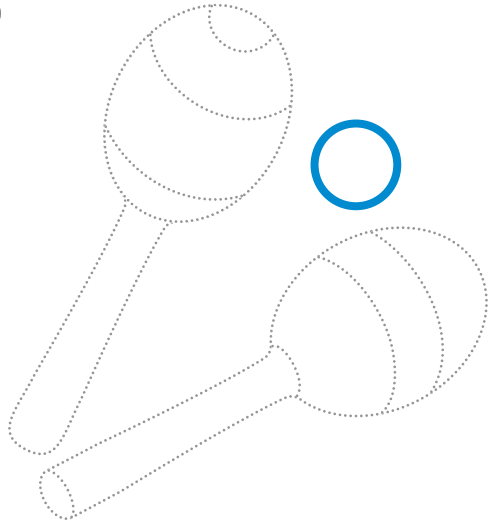

maracas

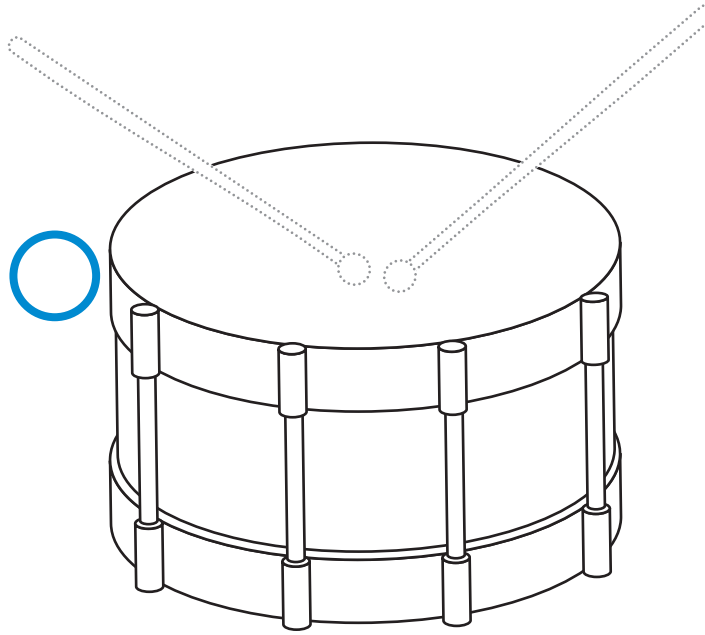

tamboril

2 Repasa y colorea.

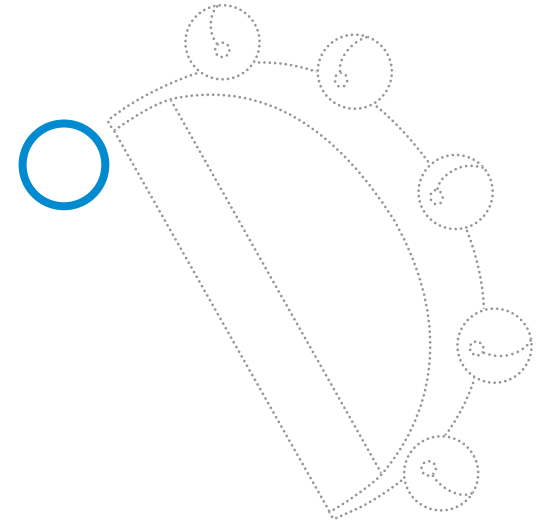

cascabeles

3 Practica estos ritmos con sílabas rítmicas, palmas e instrumentos.

Clave:

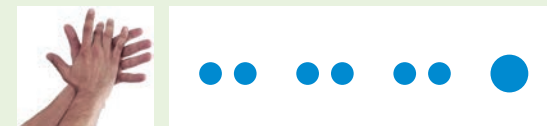
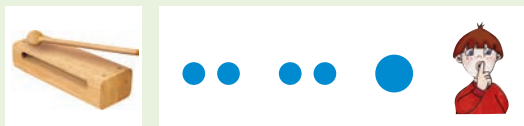
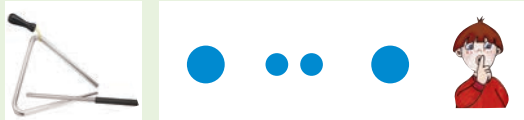
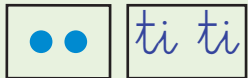
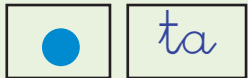

INTRODUCCIÓN



ESTROFA A



ESTROFA B



ENLACE



ESTROFA A



ESTROFA B



FINAL INSTRUMENTAL



El otoño ya se acerca

A El otoño ya se acerca,
sopla el viento en la montaña,
y arrancando va las hojas
de los árboles y plantas.

B Juntas forman una rueda
porque les gusta bailar,
van deprisa, van despacio,
marca el viento su compás.

FORMA: INTRODUCCIÓN - ESTROFA A - ESTROFA B - ENLACE - ESTROFA A - ESTROFA B - FINAL INSTRUMENTAL



1  Identifica. Colorea los árboles siguiendo las indicaciones que recibas.

botella de anís

pandereta

matasuegras

zambomba

triángulo

almirez



1 Identifica y señala el sentimiento que te inspira la música que escuchas.



miedo alegría amor tristeza



miedo
 alegría
 amor
 tristeza



miedo
 alegría
 amor
 tristeza



miedo alegría amor tristeza

obertura



Marcha Radeztky

Johann Strauss

FORMA: OBERTURA - INTRO - A - B - A

intro



A





3

La ardilla holgazana





La ardilla holgazana
no va a la escuela,
se pasa las horas
jugando a la rueda!

La ardilla holgazana
no pone la mesa,
se pasa las horas
saltando a la cuerda!

Ardilla holgazana,
haz ya tus tareas
que viene el invierno
con su nieve eterna.

(bis)

La ardilla holgazana
no hace las cuentas,
se pasa las horas
volando cometas!

La ardilla holgazana
no ayuda a su abuela,
se pasa las horas
tumbada en la hierba!

Ardilla holgazana...

José Lueiro





1 Escucha y reconoce sonidos del bosque. Imitalos con tu voz.





Los sonidos pueden bajar o subir.

1 Escucha y observa.



sonido grave



sonido agudo





2 Identifica e indica: sonido grave  o sonido agudo 





La pareja de corcheas dura lo mismo que una negra.

Cuando dos corcheas van seguidas se pueden escribir separadas  o juntas .

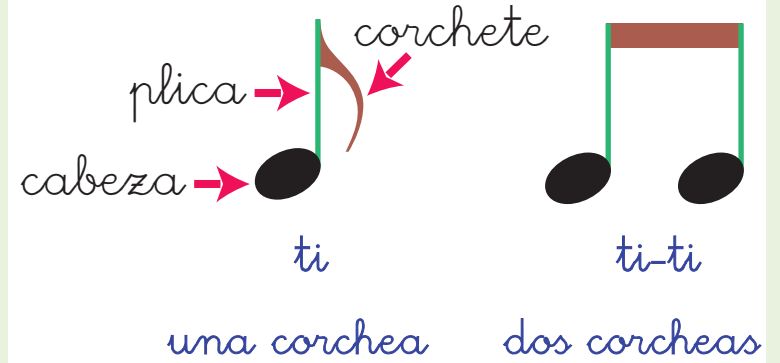

1 Repasa las corcheas y practica estos ritmos.



2 Completamos el siguiente ritmo. Practicamos con la voz y con palmas.

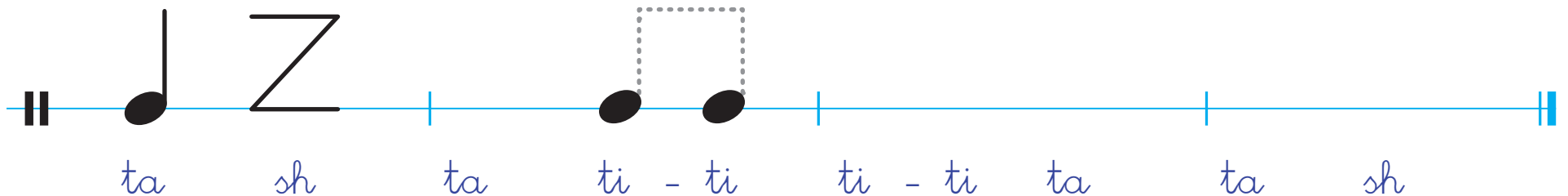



La negra, al igual que su silencio, dura un pulso.
La pareja de corcheas también dura un pulso.

1 Lee este ritmo con las sílabas rítmicas.

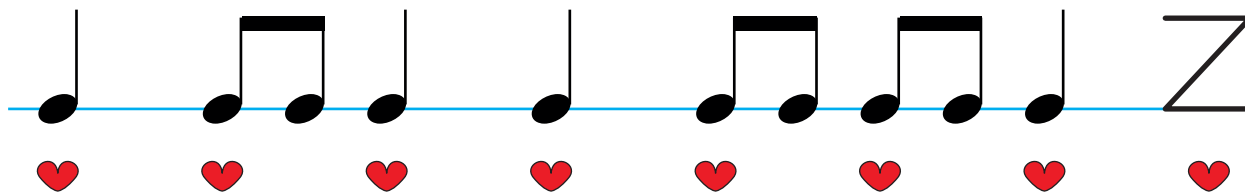

2 Completamos el ritmo.

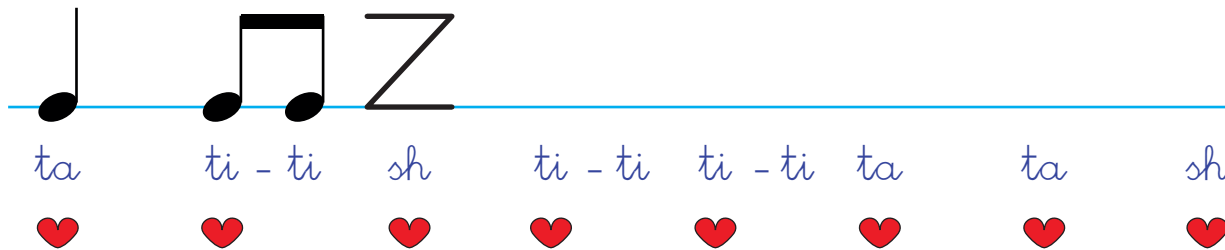

3 Coloca los pulsos y recita.

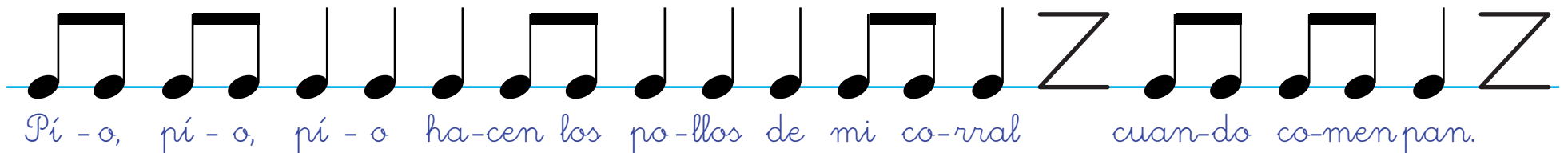



1 Recita con la letra y acompaña con percusión. Dramatiza con gestos.

Pom	pom	pom	,	no	te mue-vas más
pom	pom	pom	,	que	te ca - e - rás
Pom	pom	pom	,	no an-des	ha - cia a - trás
pom	pom	pom	,	que	tro - pe - za - rás

COREOGRAFÍA

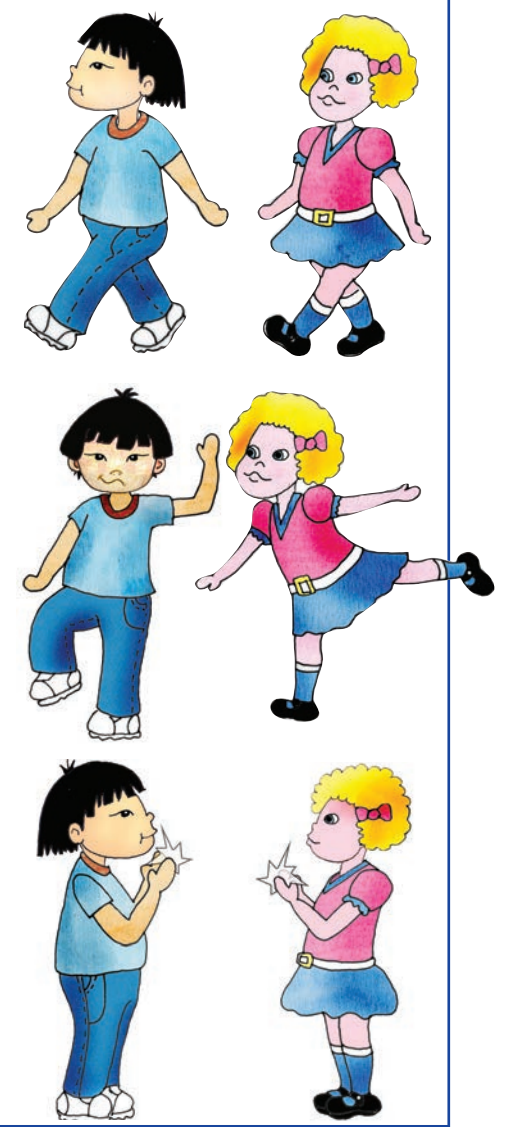



La voz humana es un instrumento magnífico y complejo, que se adapta a todo tipo de agrupaciones y repertorios. ¡La voz nace ya con nosotros, edúcala y disfruta!

1 Escucha la música e identifica las voces.



voz de niño



voz femenina



voz masculina



cuarteto femenino



coro de voces blancas



coro mixto



1 Identifica y numera.

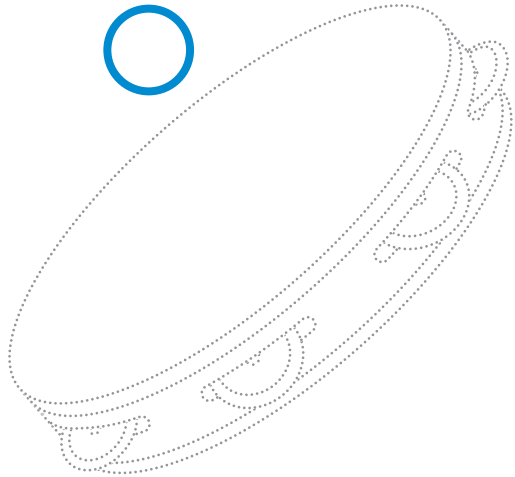

pandero

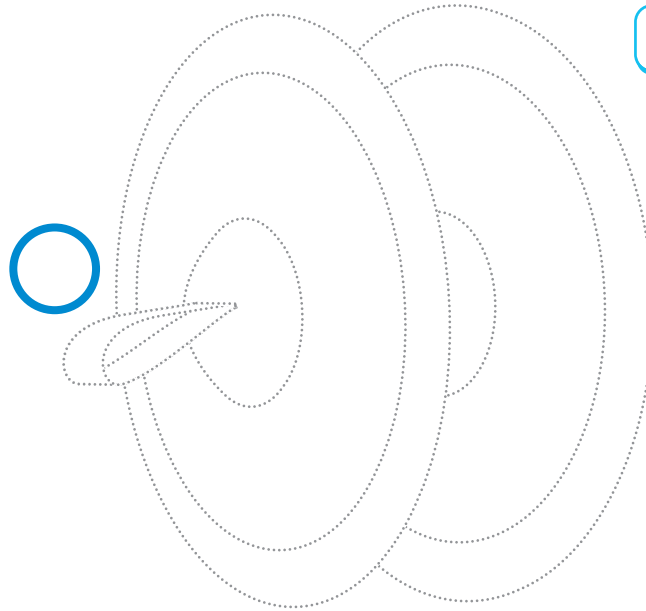

platillos



castañuelas

2 Repasa y colorea.

3 Identifica estos ritmos.





1 Interpretad por parejas con la voz: grave  o agudo 

CÓDIGO



ipío!



icloo!



iquiquiriquí!



imiau!



imuu!

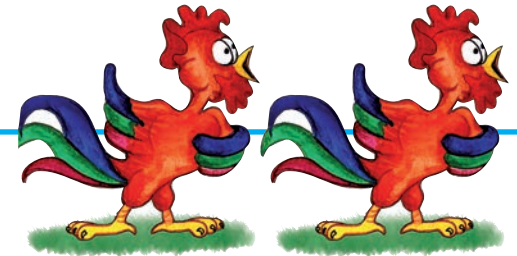
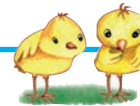
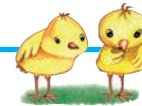
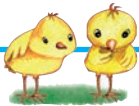
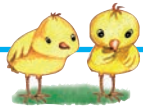

Z

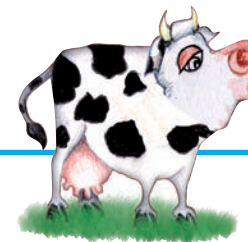
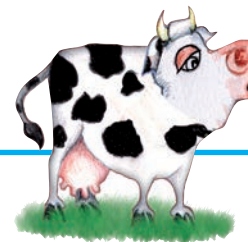
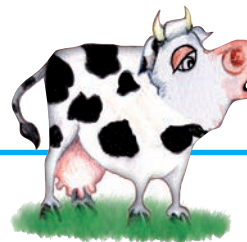

Z



EPO I TAI

Epo i tai tai e
epo i tai tai e
epo i tai tai epo.
E tuki, tuki, epo,
e tuki, tuki, epo.

popular

COREOGRAFÍA



“Epo”



“tai tai”



“e”



“tuki tuki”



“tuki tuki”

INSTRUMENTACIÓN

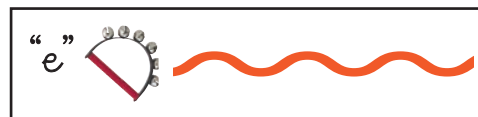

Le basque

INTRODUCCIÓN

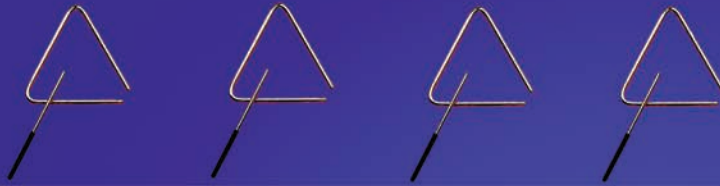

A



B

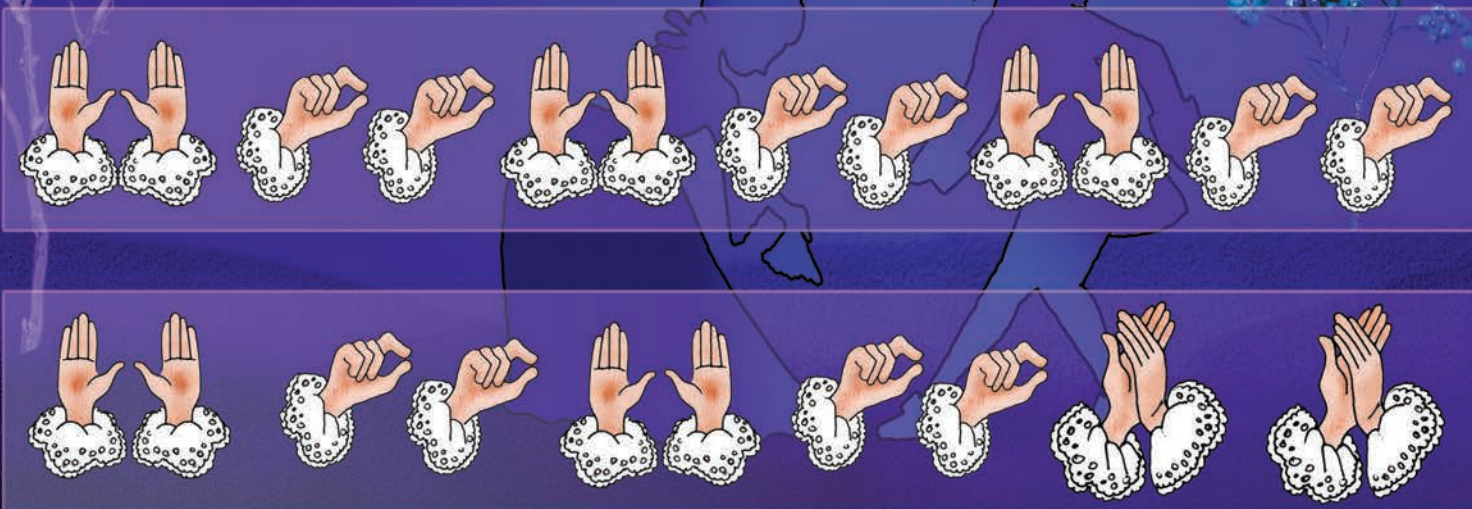

intro *ABB*
ABBABB



La Ratita Presumida



Ratita,
tú que eres tan bonita
¿Quieres casarte conmigo
y venirte a mi casita?
Soy el gallo más chulo del barrio.
Mola mazo mi crestita.
¡Kikiriki!

Ratita
tú que eres tan bonita
¿te quieres casar conmigo
y venirte a mi casita,
y venirte a mi casita?



Ay, qué guapa es mi ratita.
Ay, olé. Ay, olá.
Ay, qué guapa es mi ratita.
¿Te quieres casar conmigo
y venirte a mi casita?

Y qué guapa es mi ratita.
¿Te quieres casar conmigo,
con un vestidito blanco
bordadito de oro fino
y te quieres casar conmigo?



1  Escucha y reconoce sonidos de la granja. Imitalos con tu voz.





1  Clasifica en sonidos graves  o sonidos agudos 



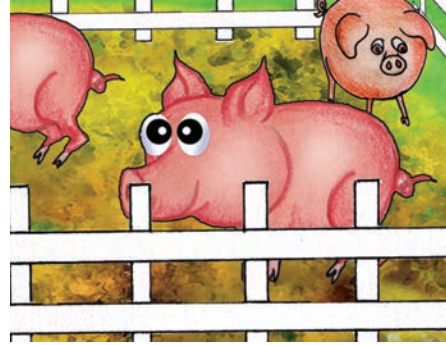









2  Identifica e indica: sonido largo  o sonido corto 











1 Escucha y escribe el orden en que suena. Practica con las sílabas rítmicas.



2 Coloca los pulsos y recita. Acompaña con percusión corporal.



Pa - to, pa - ti - to, cua, cua, cua,
 ♥

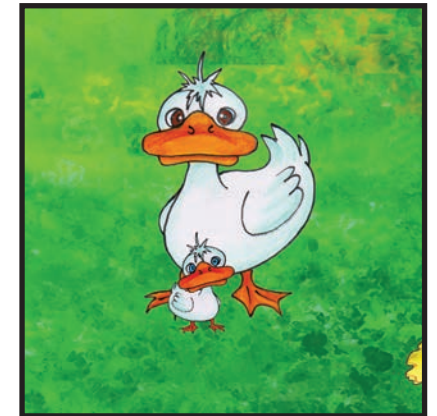

a - bre el pi - qui - to cua, cua, cua.



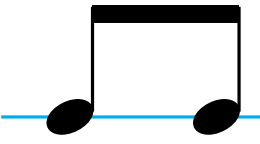
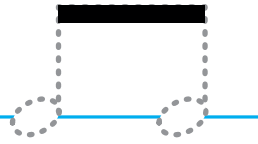

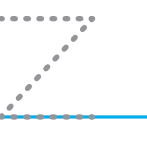

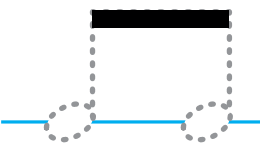

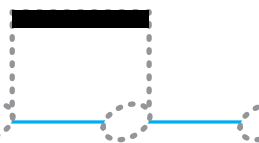
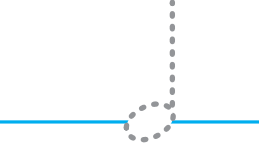
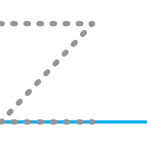



- 1 Completa el ritmo de esta canción. Lee con las sílabas rítmicas.
- 2  Canta con la letra y acompaña con instrumentos.

 Va - mos
  a la
  mar,
  tum, tum,
 

 a
  co - mer
  pes - ca - do,
  tum, tum,
 

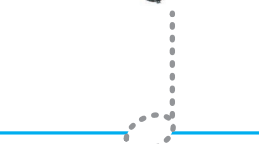
 bo - ca
  co - lo - ra - da,
  tum, tum,
 

 fri - to
  y
  a - sa - do,
  tum, tum.
 





Música y movimiento: Juego musical

A



El aprendiz de brujo (**Paul Dukas**)

B



Marcha triunfal (**Giuseppe Verdi**)

C



Los pájaros (**Camille Saint-Saëns**)

D



Gallop (**Georges Bizet**)

E

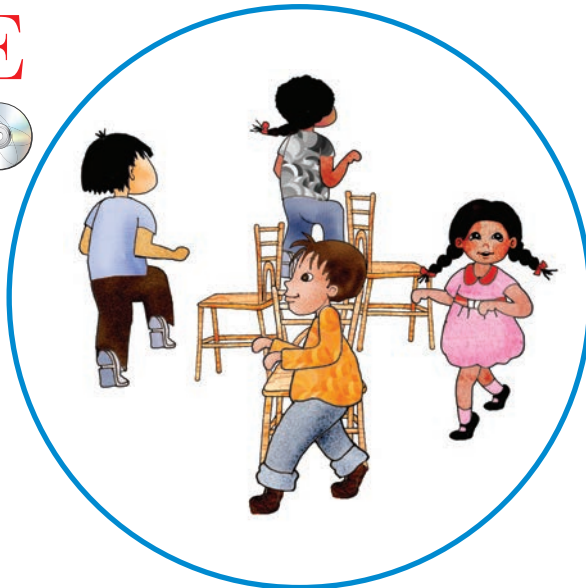

Plink, plank, plunk! (**Leroy Anderson**)

F



Montando sobre el caballito de madera
(**Robert Schumann**)



1  Identifica y numera.

2 Repasa y colorea.

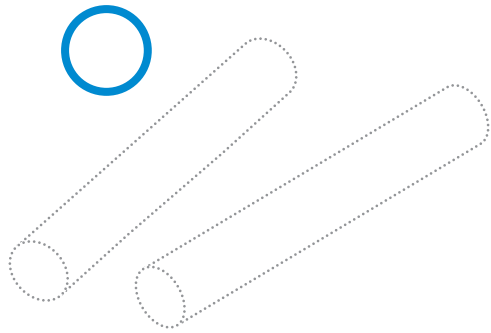

claves

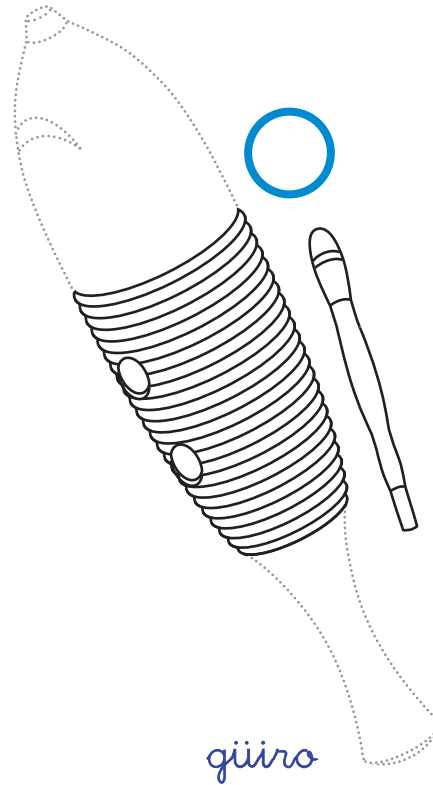

guiro

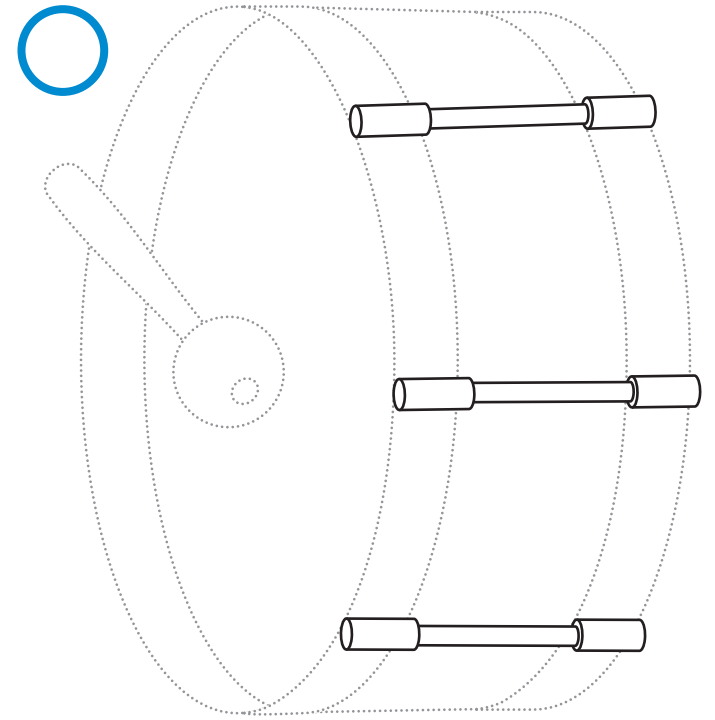

bombo

3 Interpreta estos ritmos con los instrumentos que se indican y con palmas.

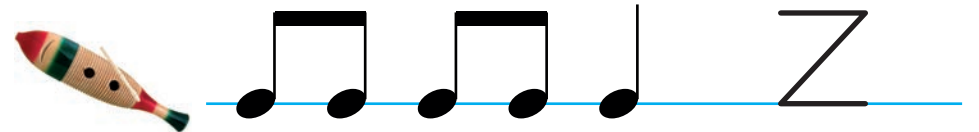
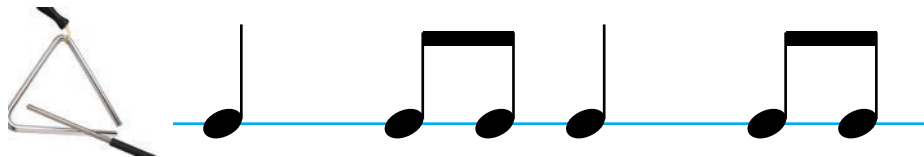
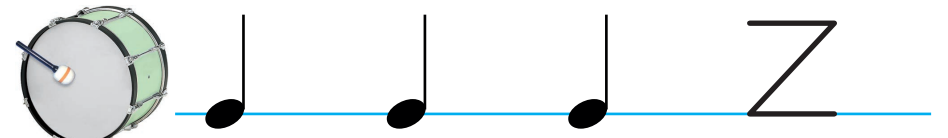
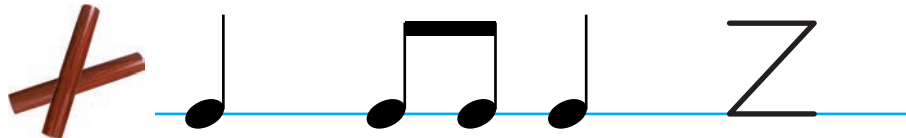



introducción



enlace



FORMA: INTRODUCCIÓN - A - ENLACE - BB
ENLACE - A - ENLACE - BB - FIN

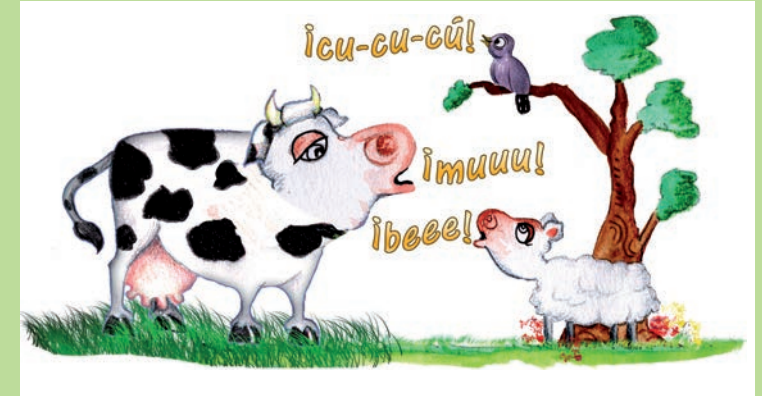

A Una oveja dijo ¡beee !
y una vaca dijo ¡muuu !
y el cuclillo desde el bosque
les contesta ¡cu-cu-cú!
y el cuclillo desde el bosque
les contesta ¡cu-cu-cú!

B ¡No puede ser, no puede ser!,
ningún mago acertará
lo que hablan entre ellos
lo que dejan de hablar. (bis)

Popular



1 Escucha e debuxa onde corresponda:



A



El vuelo del moscardón
(N. Rimsky-Korsakov)

B



El invierno (A. Vivaldi)

C



El Danubio Azul (J. Strauss)

D



Asnos salvajes (C. Saint-Saëns)

BALLET DE LOS POLLUELOS

A

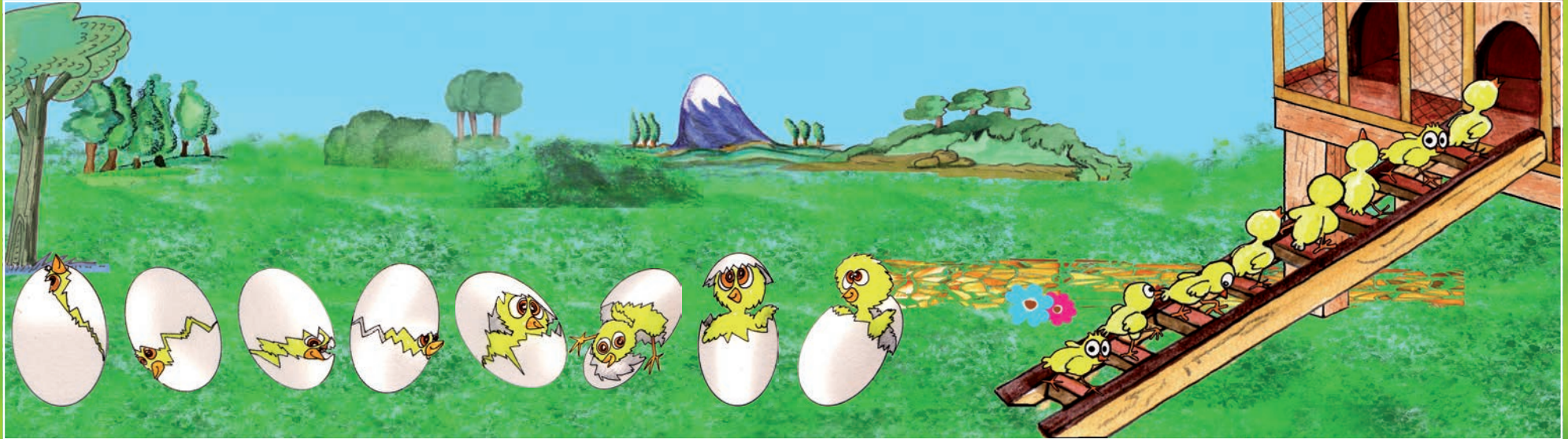

FIN



Modest Mussorgsky

B

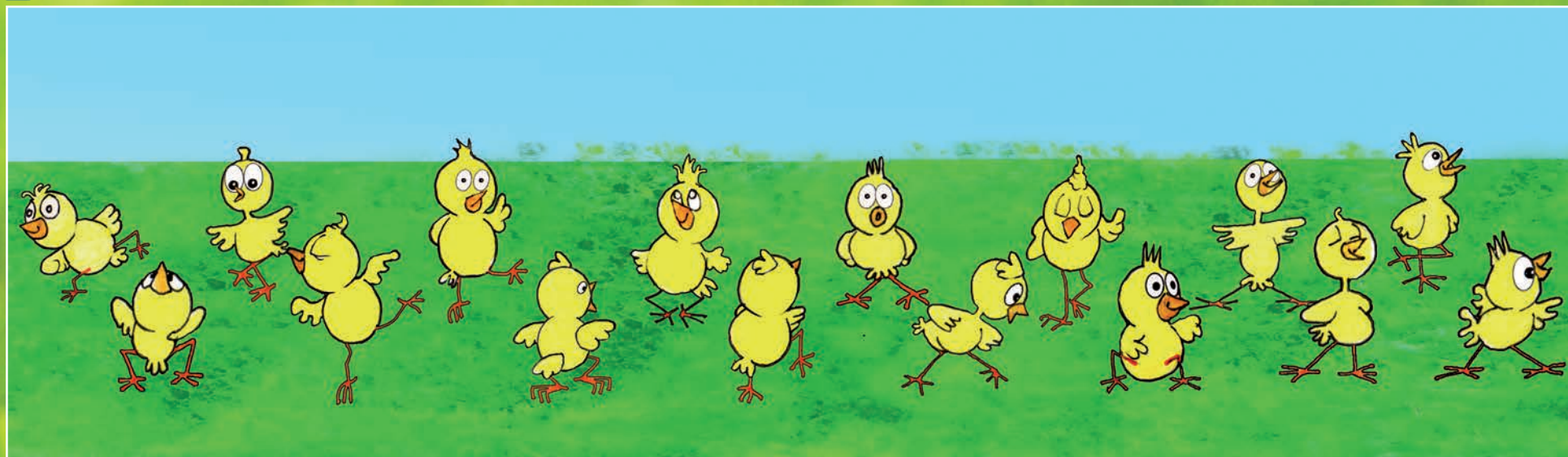

C



repetimos desde A hasta FIN

5



Cenicienta

Ruke di gak, ruke di gak;
el zapato no le va,
le apretuja la puntita
o le sobra por detrás.

Zapatitos de cristal,
zapatitos de charol,
las doncellas del lugar
se los prueban con dolor.

Ruke di gak, ruke di gak;
el zapato bien le está;
ni le aprieta por delante;
ni le sobra por detrás.

Zapatitos de charol,
zapatitos de cristal,
se los prueba con amor,
la sirvienta del hogar.

¡Cenicienta es su nombre,
y con el rey se va a casar!



José Lueiro





1  Escucha y reconoce sonidos de la casa. Imitalos con tu voz y con gestos.







1  Identifica.













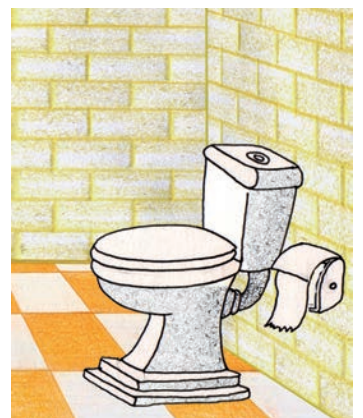





2 Clasifica.

agudo 

grave 

largo 

corto 



El orden de las notas es siempre el mismo: *do re mi fa sol la si*.

1 Recita varias veces las notas en sentido descendente.

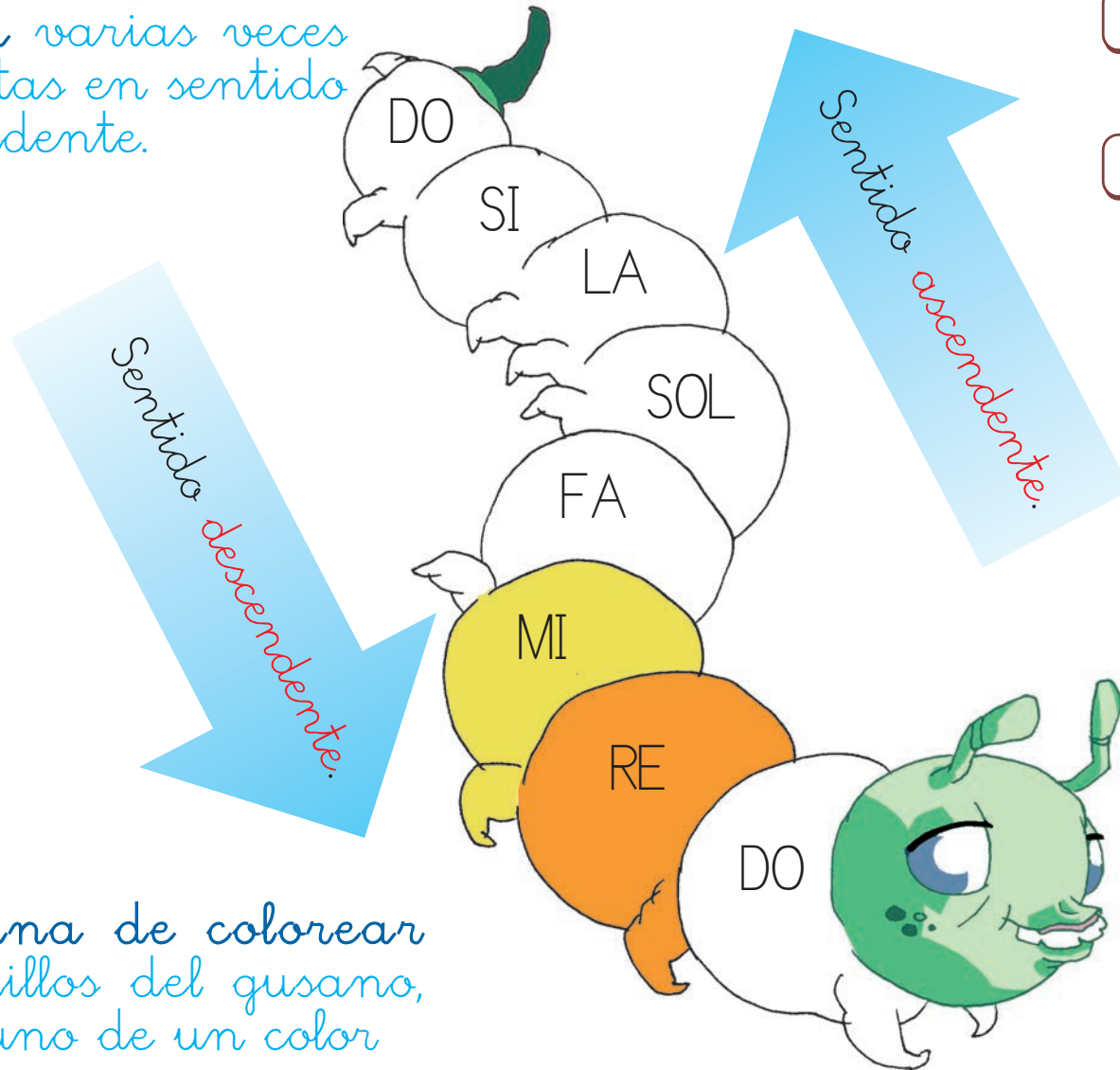

2 Ahora, recitalas en sentido ascendente.

3 Hacemos dos grupos.

Grupo 1: recita en sentido ascendente.

Grupo 2: recita en sentido descendente.

4 Termina de colorear los anillos del gusano, cada uno de un color





Las notas musicales se escriben en el pentagrama.
 La nota *mi* se coloca en la primera línea.
 La nota *sol* se coloca en la segunda línea.

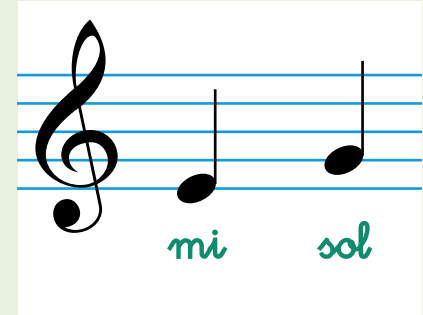

1 Escribe el nombre de las notas.

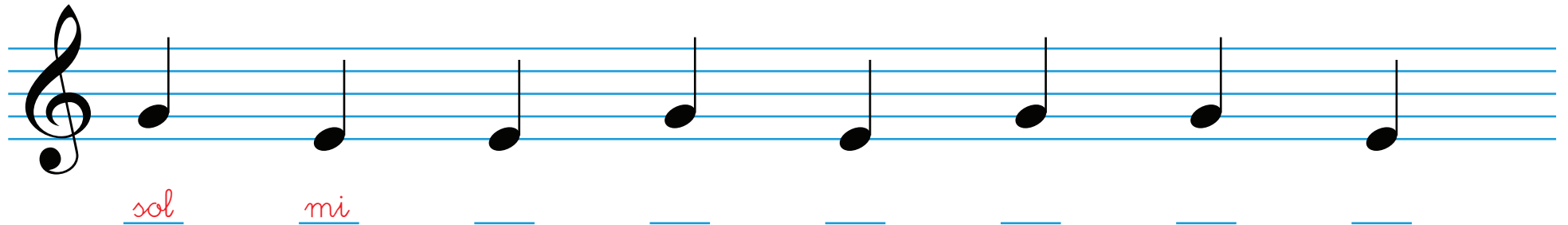

2 Dibuja las notas en el pentagrama.





1 Escribe la canción en el pentagrama. Cantamos y jugamos con la pelota.



Z □ □ □ □ □ □ □
 sol sol mi mi sol sol mi mi sol sol mi mi sol sol

Musical staff with notes and lyrics: *La pe - lo - ta sal - ta y bo - ta, la pe - lo - ta se es - ca -*

| □ □ □ □ □ □ □ | Z
 mi sol sol mi mi sol sol mi mi sol sol mi mi sol sol mi

Musical staff with notes and lyrics: *pó. La pe - lo - ta sal - ta y bo - ta, la pe - lo - ta ya vol - vió.*

Acompañamos:





Escucha estos bailes y danzas populares.





1  ¿Qué instrumento suena en cada serie?

A

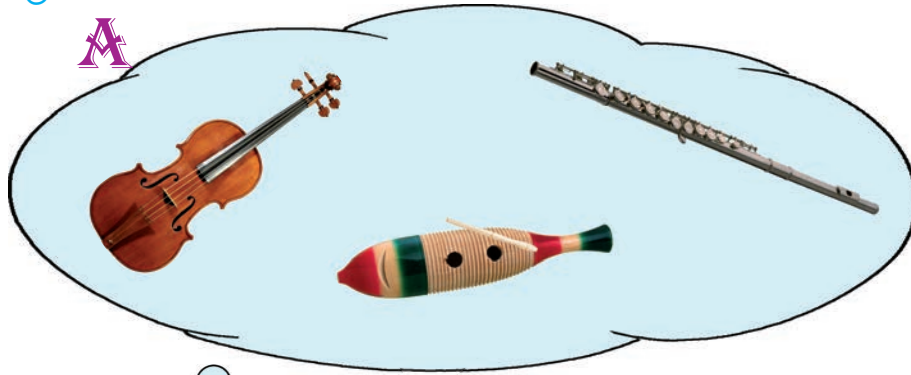

cuerda viento percusión

B

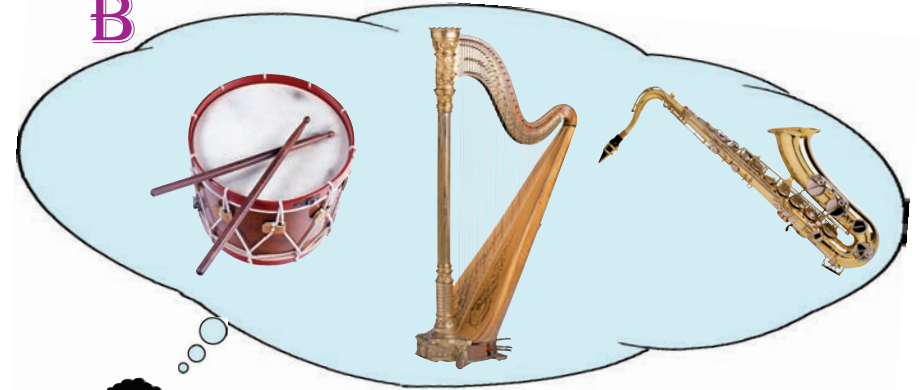

cuerda viento percusión

C



cuerda viento percusión

D

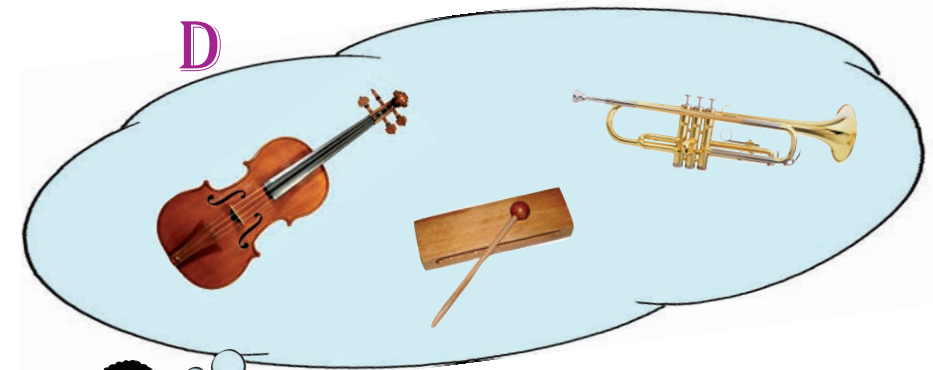

cuerda viento percusión



1 Escucha la música y canta la canción acompañándola con gestos.



Tin, ton
tiqui tiqui ton
tiqui tiqui titi



fa la la



TON.

Clave:

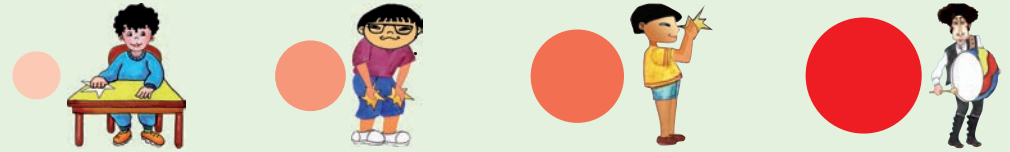

Acompañamos con percusión

|| ● ● | ● ● ● ● ● | ● ● ● ● ● ● | ● ● ● ● ● | ● ● ● ● ● |

Tin, ton ti - qui - ti - qui ton, ti - qui - ti - qui ti - ti fa la la.

|| ● ● | ● ● ● ● ● | ● ● ● ● ● ● | ● ● ● ● ● | ● ● ● ● ● |

Tin, ton ti - qui - ti - qui ton, ti - qui - ti - qui ti - ti ton. *repetimos*

J. Brahms Danza Húngara N°5

A

2

veces



B

2

veces

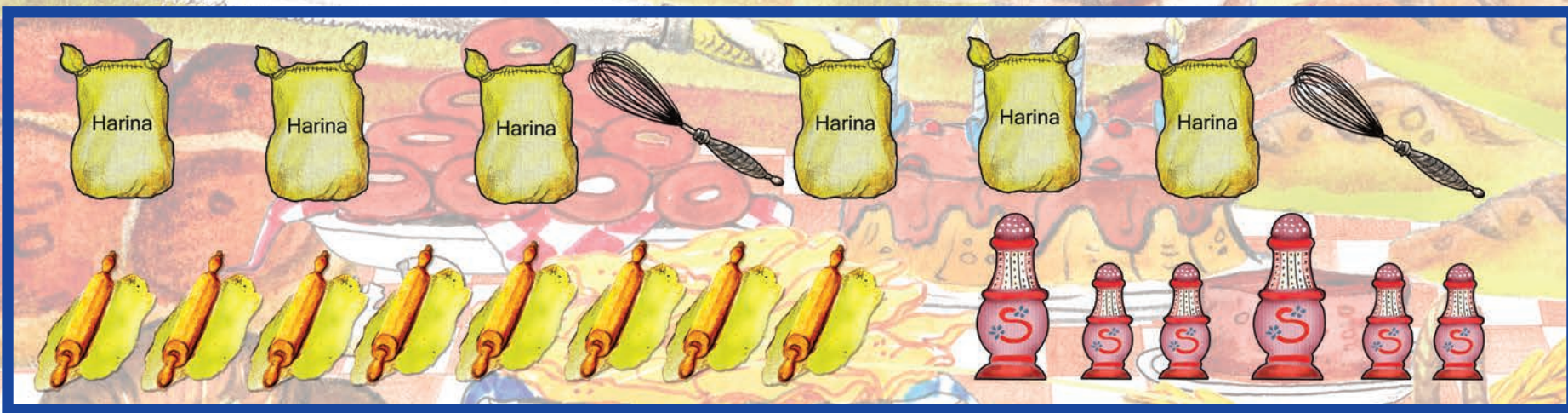

C



2 veces



D.C

4 veces

6

El soldadito de plomo



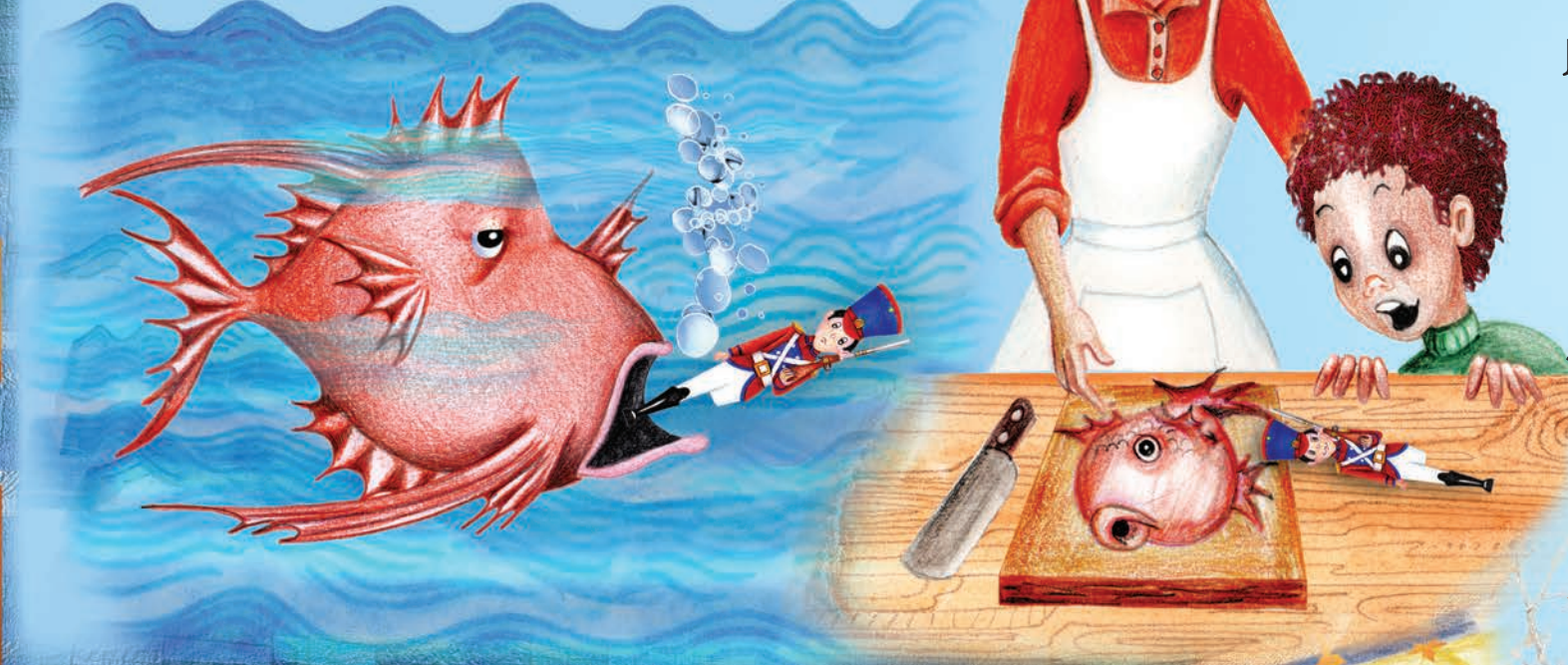

Mi madre es una cuchara,
mi padre es un cucharón;
yo soy un soldado cojo,
de plomo es mi corazón.

No late, late mi pecho
porque alguien me lo robó,
una bella bailarina
tan cojita como yo.

¡Capitán, capitán,
yo a la guerra no me voy!
¡Capitán capitán,
yo me quedo con mi amor!

Mi madre es una chaqueta,
mi padre es un chaquetón;
yo soy una bailarina,
de trapo es mi corazón.

Mi cuerpo es de fina seda,
mis huesos son de algodón;
mis sueños de un soldadito
que marcha sobre un tacón.

¡Capitán, capitán...





Los sonidos de nuestro entorno: Las profesiones

1  Identifica los sonidos. Escoge una cualidad para cada uno.



rápido lento



corto largo

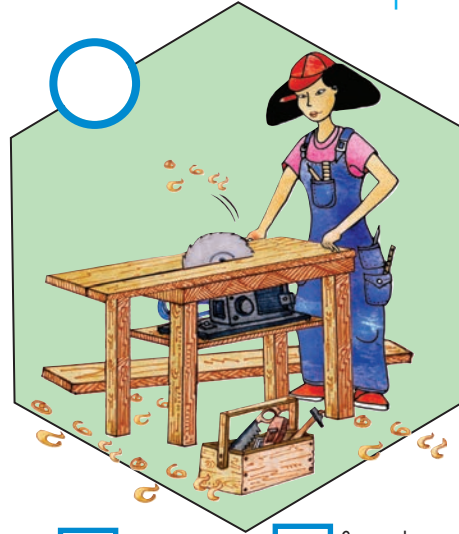

rápido lento



corto largo

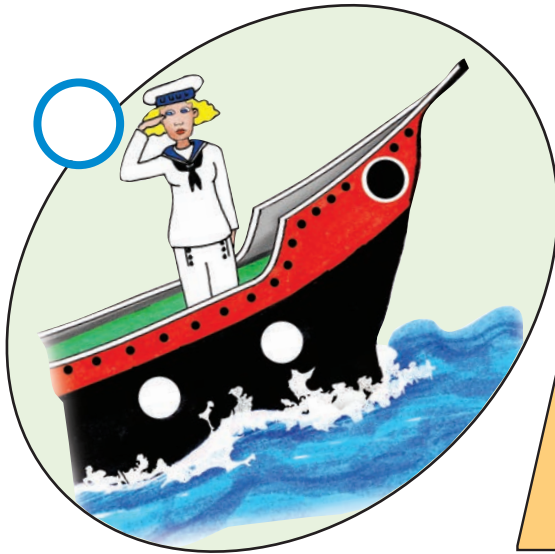

grave agudo

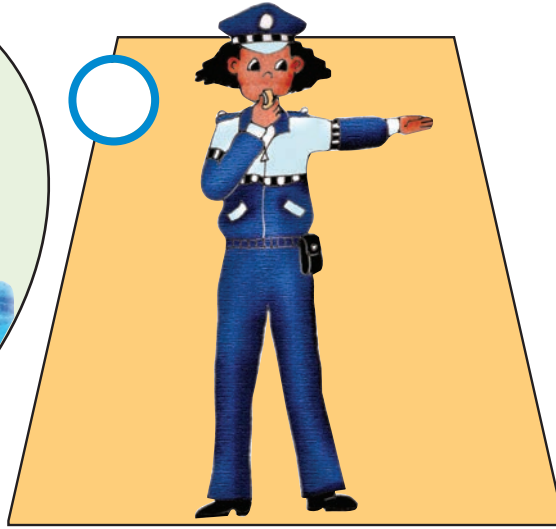

fuerte débil

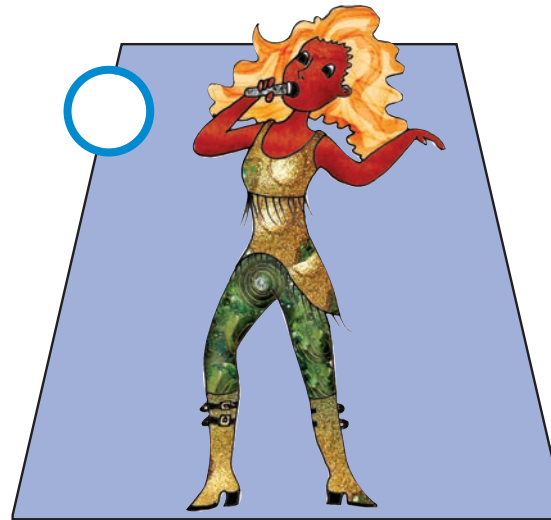

grave agudo

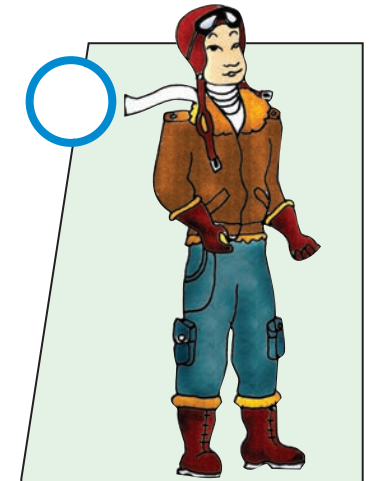

fuerte débil



1) Escribimos el ritmo.

ta ti ti sh ti ti ti ti ta sh ta

ta ti ti sh ti ti sh ti ti ta sh

2) Tocamos con percusión el siguiente ritmo.

3) Inventamos ritmos con:





Conocemos:

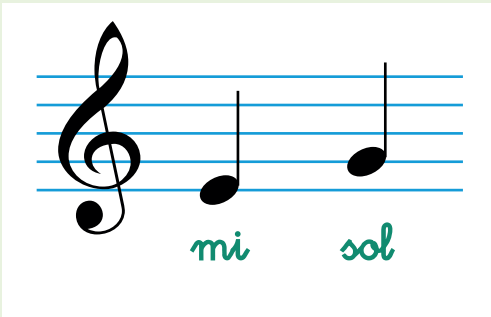

Aprendemos:

La nota la se escribe en el segundo espacio del pentagrama



1 Escribe el nombre de las notas.

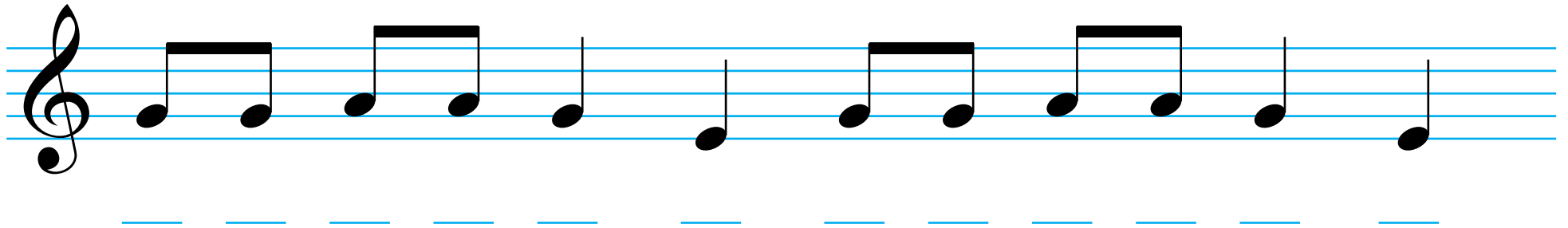

2 Identifica los siguientes esquemas melódicos.

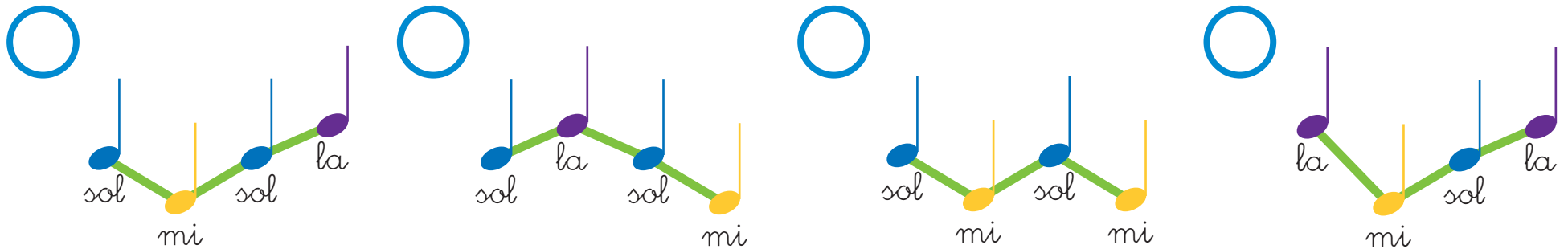



1 Coloca los pulsos y canta la canción con las sílabas rítmicas y la letra.



U - na dos, tres y

cua - tro, Mar - ga - ri - ta tie - ne un

ga - to con los o - jos de cris -

tal que pa - re - ce un a - ni - mal.



Popular



1  Fíjate en las imágenes mientras escuchas la música y la historia. Luego, relaciona la música con las imágenes.



2 Por grupos, creamos nuestra propia historia.



Escucha la música de la canción antes de dramatizarla.

Camille Saint-Saëns

FORMA: A - B - A - B - C - D

A



B

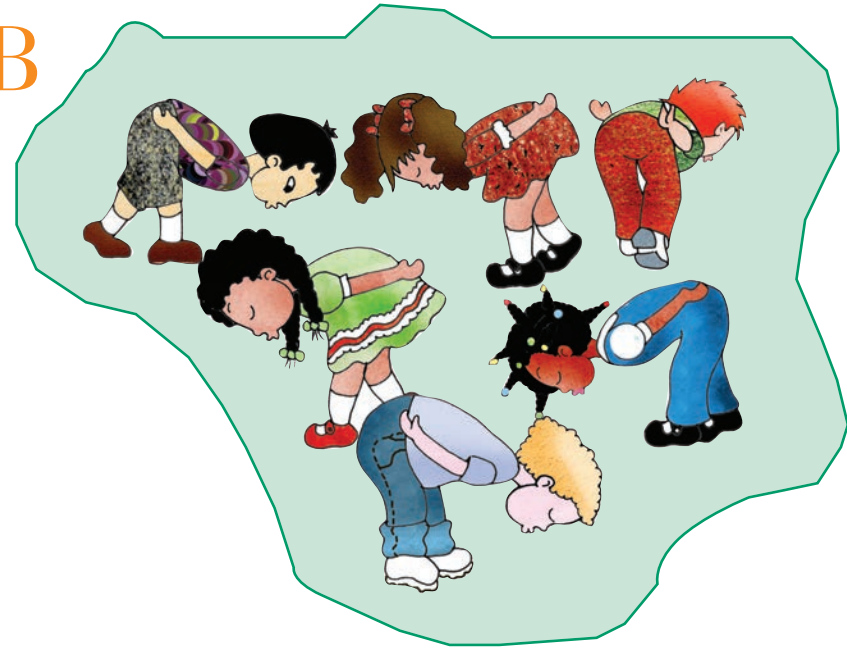

C



D





Cultura musical: Las familias de percusión

1  Identifica y relaciona con flechas, según su familia.



familia de madera

familia de metal

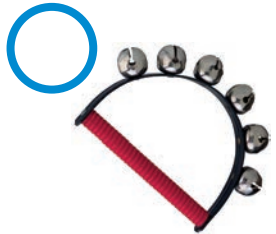

familia de parche

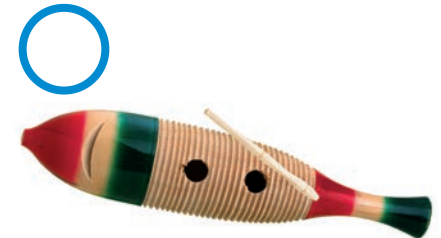
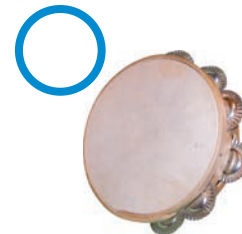
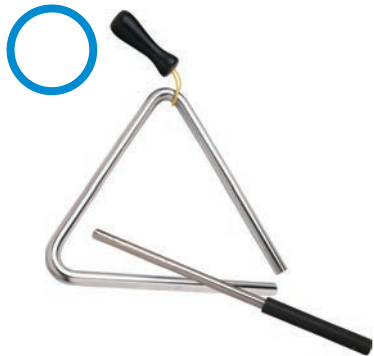



1 Escucha y observa cómo suenan los siguientes instrumentos.

A

Kenia (África)

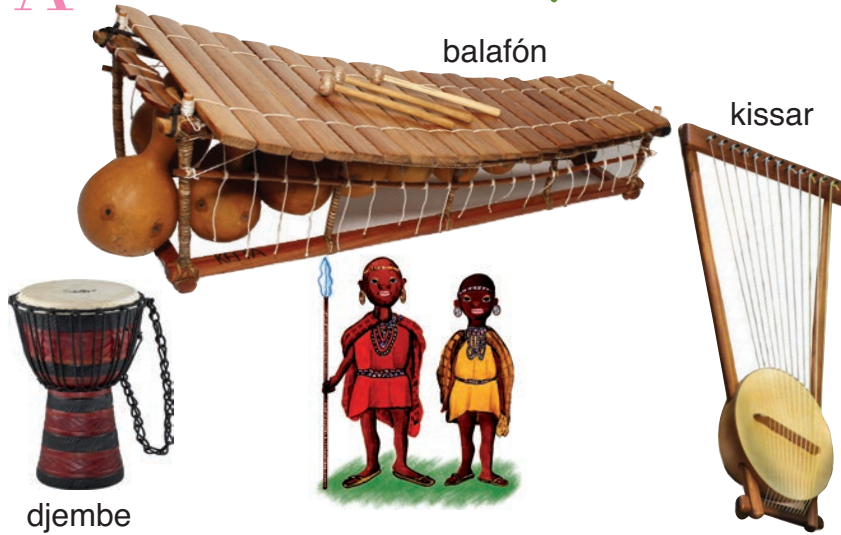

B

Rusia (Europa)



C

China (Asia)



D

Perú (América)





1  ¡Presta mucha atención o tu equipo perderá una prenda!

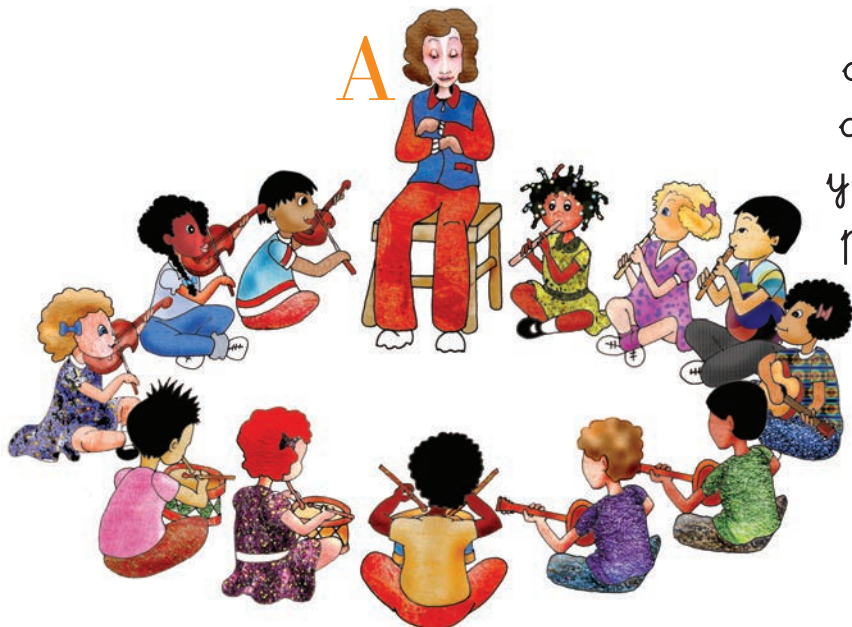

Antón, Antón,
Antón Pirulero,
cada cual, cada cual
que atienda su juego,
y el que no lo atienda,
pagará una prenda.



Sigue el juego con estos instrumentos. **Colorea.**

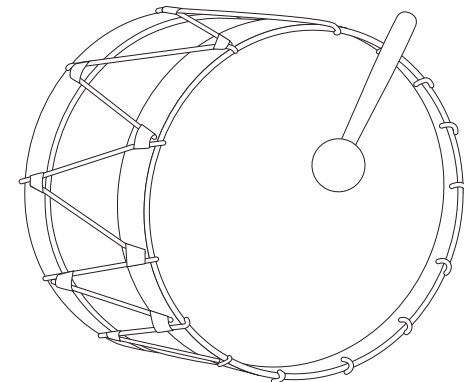
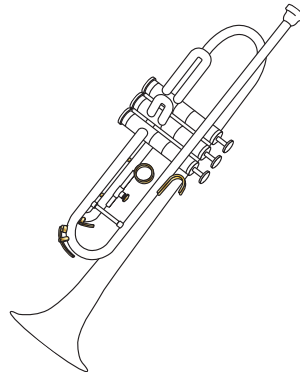
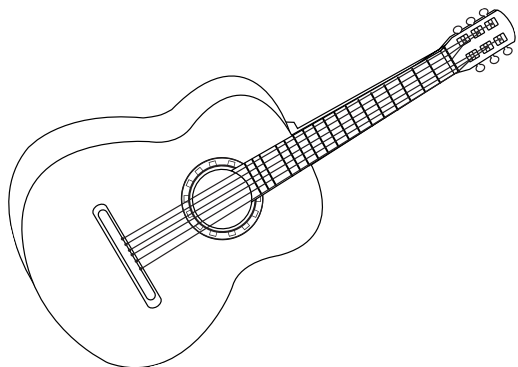
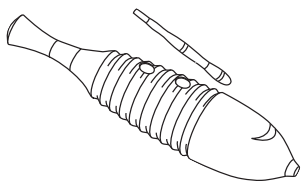



COMPOSITOR



Escribe la partitura.
Decide los instrumentos
que van a tocar.

PARTITURA

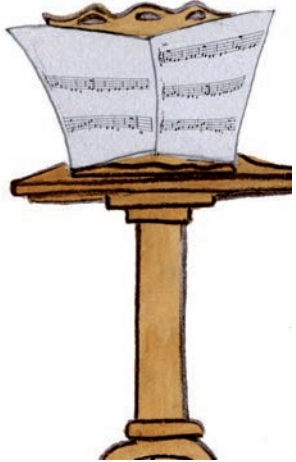

Contiene la obra e indica la parte que debe tocar cada instrumento.

1 ¿Reconoces algún componente de esta banda?



DIRECTOR

Da la entrada a los instrumentos principales.
Marca la velocidad y la fuerza de la obra.
Dirige con las manos y gestos, ayudado de una batuta.



PÚBLICO



Debe escuchar con atención y silencio.

INSTRUMENTISTAS

Estudian su partitura.
Deben estar muy atentos a los gestos del director durante los conciertos: pianista, flautista, trombonista...



PIANISTA

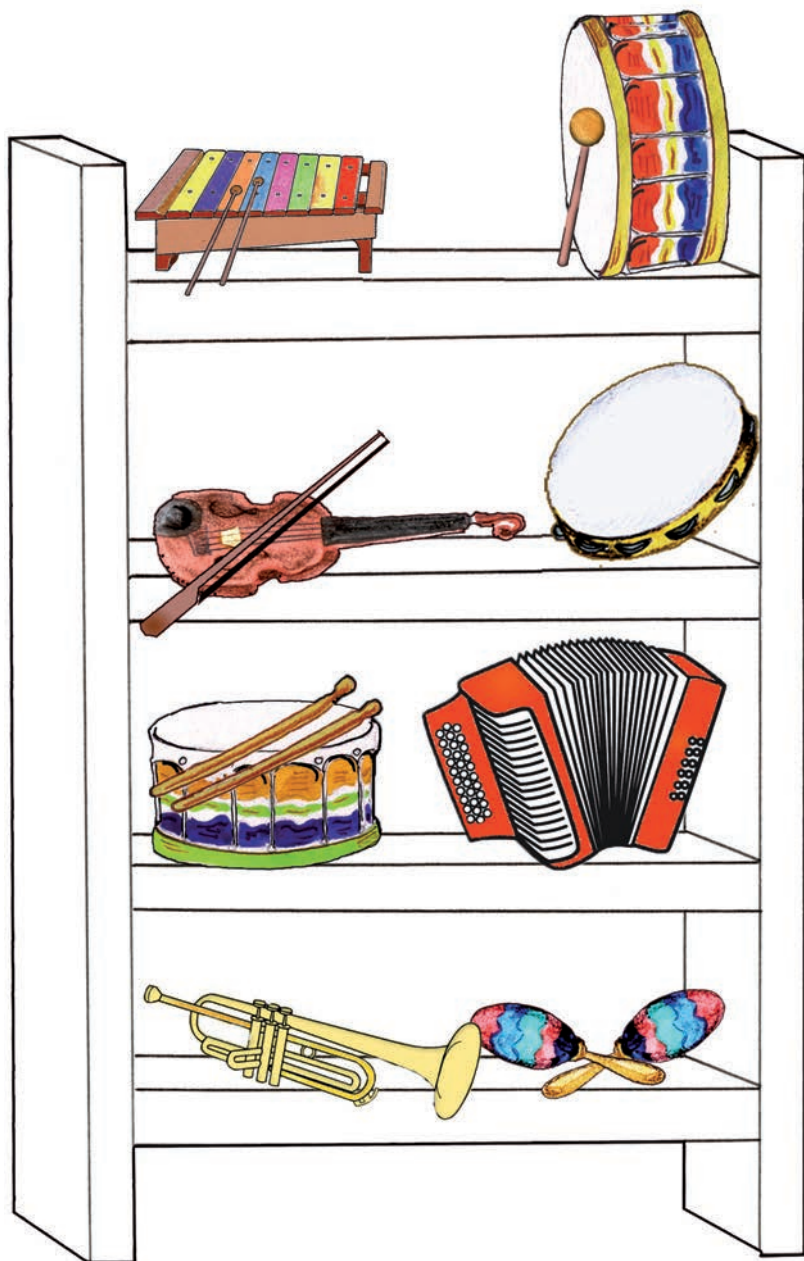

1 **Busca** en la sopa musical el nombre de los instrumentos que aparecen en la estantería.

2 **Colorea** la estantería.

X	F	A	N	P	U	C	H	A	T	R	N
I	T	R	O	M	P	E	T	A	A	K	B
L	P	O	C	G	A	T	Q	G	M	T	Q
V	I	O	L	I	N	T	M	X	B	R	S
F	C	D	K	G	D	V	S	I	O	E	A
O	J	E	D	F	E	M	M	L	R	M	F
N	B	A	C	O	R	D	E	O	N	P	T
O	W	N	O	R	E	G	A	F	V	Q	A
Q	V	Z	P	A	T	D	E	O	E	T	M
M	A	R	A	C	A	S	R	N	C	A	B
O	X	T	L	B	V	I	B	O	M	B	O
U	U	P	O	L	V	U	X	K	P	T	R



Esta marcha del compositor checo Julius Fučík es música imprescindible en los espectáculos circenses.

FORMA: INTRO - A - A - B - B

 un pulso

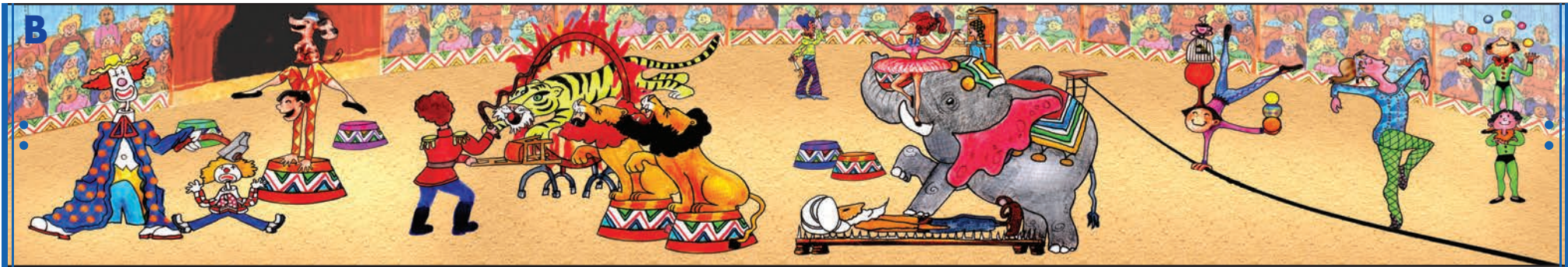
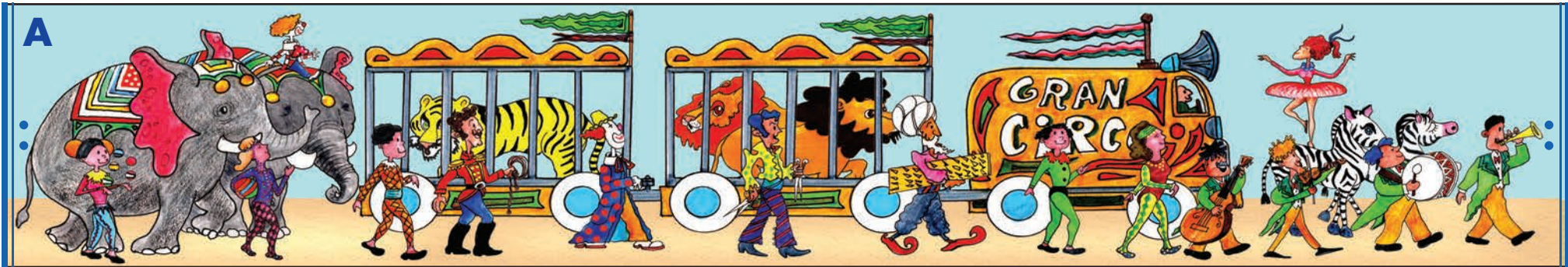

Dirección y proyecto editorial

Telmo Eiriz López

Ingeniero de sonido

Fernando Campos Dono

Dirección coral

Alfonso Deus Santos

José Lueiro Lemos

Voces

*Escuela Municipal de Artes Escénicas da Estrada
Colegio Obradoiro (A Coruña)*

Ilustraciones

*Marta Rivera Ferner
Alberto Urcaray Rodríguez*

Diseño y maquetación

Bernardo Romay Mos

Imprime

Galigraf Galicia

Autores

Ana M^a López Rodríguez

José Lueiro Lemos

Juan Francisco Moreno

Francisca Muñoz-Quirós Angulo

Jeremías Tejera Torres

Asesor lingüístico

José Sánchez Puga

© GALINOVA EDITORIAL, SL

Depósito legal: C 855-2014

ISBN: 978-84-9737-219-0

2ª edición - julio 2014

Printed in Spain

Queda prohibida, salvo excepción prevista por la Ley, cualquier forma de reproducción, comunicación pública o transformación de esta obra sin contar con la autorización de los titulares de la propiedad intelectual.

La infracción de los derechos mencionados puede ser constitutiva de delito contra la Ley de Propiedad Intelectual, artículos 270 y siguientes, del Código Penal.

Reservados todos los derechos. GaliNova Editorial SL puso todos los medios a su alcance para reconocer en citas o referencias los eventuales derechos a terceros y cumplir todos los requisitos establecidos por la Ley de Propiedad Intelectual.

El libro **Melodía 1** es una obra colectiva, creada y coordinada por el Departamento de Ediciones de Galinova Editorial Primaria.

GALINOVA EDITORIAL, SL

C/ Rafael Báñez Vázquez, 8

15009 A CORUÑA

Teléfono: 981 139 057

Fax: 981 175 364

galinova@galinovaeditorial.com

www.galinovaeditorial.com